

E-Box-48100R

User Manual



V1.2

DLG E-BOX-48100R LFP Battery User Manual

Dear customer,

This is your DLG E-BOX-48100R LFP battery for home energy storage system. We provide safe, well-designed and high-performance standard LFP battery packs for you. The battery pack is compact, easy to install, free of maintenance and used as the building block of energy storage system by assembling in parallel. It is widely applied in home applications, small commercial and industrial energy storage system as well as Telecom stations.

This manual contains all the information necessary to install, use and maintain the LFP battery. We kindly ask you to read this manual carefully before using the product.

This manual is meant for the installer and the user of the LFP battery. Only trained and qualified staff may install and perform maintenance on the LFP battery.

The boundaries of its use, as described in this manual should be kept in mind. The LFP battery may not be used in medical or in aviation related applications. The LFP battery may not be used for any purposes other than described in this manual. Using the LFP battery for any other purpose will be considered improper use and will void the warranty of the product. DLG cannot be held responsible for any damage caused by improper, incorrect or unwise use of the product. Read and understand this manual completely before using the product. During the use of the product, user safety should always be ensured, so installers, users, service personnel and third parties can safely use the LFP battery.

This is the original manual, keep it in a safe location! Please consult <http://www.dlg-battery.com> for the latest version of all manuals.

DLG (SHANGHAI) Electronic Technology CO., LTD.

Add: No.3492 Jinqian Road, Qingcun Town, Fengxian District, Shanghai, China.

Website: <http://www.dlg-battery.com>

Tel: 86-21-57474356

Email: ess_support@dlgbattery.cn





1 Specifications

Table 1-1 Battery Pack Specifications

Battery Model	E-BOX-48100R
Chemistry	LFP
Nominal Voltage	51.2V
Voltage Range	44.8V-57.6V
Nominal Capacity	100Ah
Nominal Energy	5.12kWh
Unit Dimension	L480mm* W620mm * H117mm (2.6U)
Unit Weight	51kg
Standard Charge Current	50A
Maximum Charge Current	50A
Standard Discharge	50A
Maximum Discharge Rate	50A
Round-Trip Efficiency	≥95%
Communication Protocol	RS232, RS485, CAN
Cycle Life	≥6000cycles@0.5C/0.5C @90%DOD, ret@80%, 25°C
Calendar Life	≥10years
Operating Temperature	Charge: 0°C~ 45°C, Discharge: -20°C~ 55°C
Certificates	IEC62619 / UN38.3
Storage Temperature	Within 1month: -20~45°C 1-3months: -20~35°C

3-12months: 20~25°C

1.1 Product standard configuration

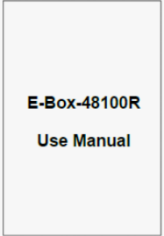
Items	Quantity	Specifications	Pictures
E-BOX-48100R	1pcs	51.2V/100Ah LFP pack; including BMS, three interfaces (CAN/RS-485/RS232), 2 Link ports, LED power indicator and insulated coating metal case.	
Power Cable (optional)	1set	Connect battery to battery; 0.2m; Positive and negative	
Communication Cable (optional)	1pcs	Connect battery to battery; 0.2m;CAN or RS485 communicate	
Ground cable (optional)	1pcs	1m	
User Manual (optional)	1pcs	Please read the User manual before you use this product.	

2 Interface and protection functions

2.1 Battery front panel



2.2 Battery front panel schematic

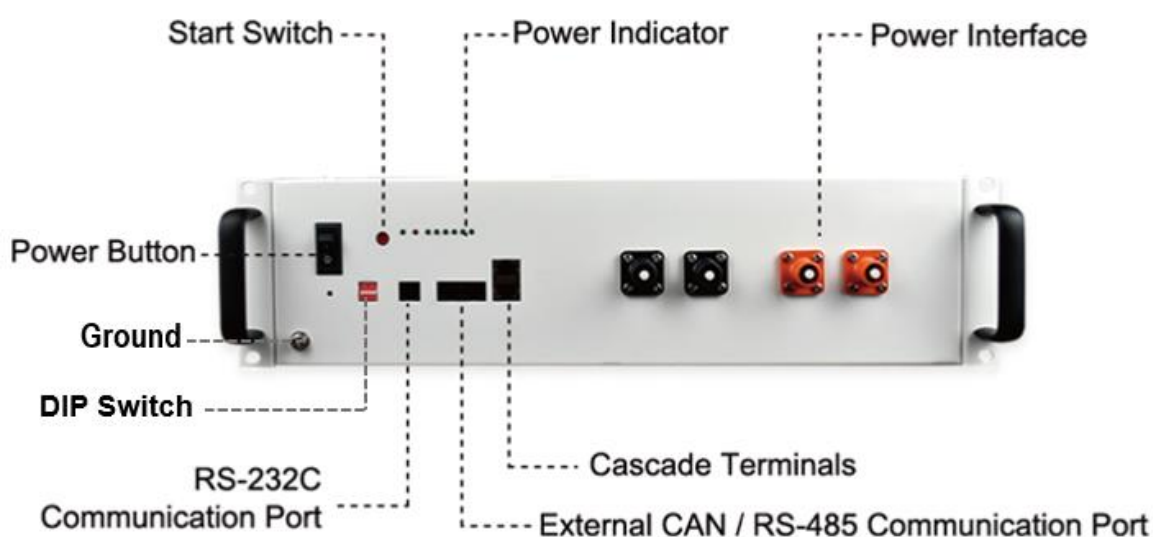

2.3 Components

No.	Name	Label	Functions description
1	Ground		Grounding
2	Power button	POWER	Power button. When switched to "ON", the system can be activated by the "SW" key or external power supply; when switched to "OFF", the system is off.

3	Soft start switch	SW	Press and hold this button for 1 second while the switch key is "ON" to enter Start or Sleep mode
4	DIP switch	ADD	Select the match manufacturer, see the match list(appendix A)
5	Running lights	RUN	Green lights. The lights flash when Standby. The lights are constantly on when charging. The lights flash when discharging.
	Alarm indicator	ALM	Red light. The lights flash when Alarm. The lights are constantly on when Protected.
	Capacity indicator	CHARGE	A total of 6 green lights showing battery capacity, each representing 16.7% of SOC.
6	External CAN communication port	CAN	Communication with external devices
7	External RS-485 communication port	RS485	Communication with external devices
8	Cascade terminal	Link Port	Used for master-slave cascade communication. Connected with a standard direct-connected network cable, the master is connected to PORT1, and the slave is connected to PORT0.
9	Input and output interface (negative)	“-“	Negative input and output interface
10	Input and output interface (positive)	“+“	Positive input and output interface

2.4 Battery Management System (BMS)

DLG BMS is widely applied in home energy storage applications in America, China, Europe and Australia etc. The BMS manages and protects the battery system stably and accurately by measuring &

collecting battery data, thermal management, balancing, communication, giving out alarms & protection etc. The high performance of BMS is guaranteed by adopting Automotive-level chips and self-developed sophisticated DLGOS BMS software.

3 Operating Environment

Battery operating environment requirements:

Operating Temperature: -20°C~55°C

Relative Humidity: 20%-80%, no condensation

Altitude: <4000m

Site environment requirements: Keep away from heat source, avoid direct sunlight, no corrosive gas, no explosive gas, no insulating gas, no insulating conductive dust.

4 Packaging, transportation, storage requirements

4.1 Transportation

Always check all applicable local, national, and international

regulations before transporting an LFP battery.

During the transportation, protected the battery from severe vibration, shock or squeezing during transportation, as well as to prevent sun and rain.

During the loading and unloading process, the battery should be handled lightly and protected against falling, rolling and heavy pressure.

4.2 Storage

Follow the storage instructions in this manual to optimize the lifespan of the LFP battery during storage. If these instructions are not followed and the LFP battery has no charge remaining when it is checked, consider it to be damaged. Do not attempt to recharge or use it. Replace it with a new LFP battery.

See previous storage temperature conditions.

The self-discharge of the LFP battery is 1-2% per month. Keep the battery SOC to 40%-60% during storage.

1. Disconnect the LFP battery from all loads and, if present, the charging device.
2. Store the battery in a cool and dry place without direct sunshine.

2. Keep the battery away from corrosive substances, inflammable and explosive material as well as hazardous gases.

4. For long-term storage (>6months), charge the LFP battery to more than 80% of its rated capacity before storage. The battery needs to be recharged every 6months to more than 80%of the rated capacity.

5 Installation and configuration

5.1 Installation preparation

5.1.1 Safety Requirements

Only those who have been trained in the power system and have a good knowledge of the power system are allowed to install the device. Always observe local safety regulations and the safety requirements

listed below during installation process.

Before installing or removing the device, make sure that the power system is not powered and that the battery device is turned off. Distribution cabling should be reasonable and with protective measures to avoid being touched during operation.

5.1.2 Checking the operating environment

The operating environment should meet the requirements described in Chapter 3, “Operating Environment”. Otherwise, it needs to be adjusted and re-examined.

5.1.3 Tools

The tools that may be used are shown in Table 5-1.

Table 5-1 Tools

Tools	
Screwdriver (Slotted, Phillips)	Multimeter
Wrench	clip-on ammeter
Diagonal pliers	Insulating tape
Thermometer	Pliers
Anti-static wrist ring	Clip Pliers
Tapes	Strippers

5.1.4 Technical preparation

Electrical interface settings:

If the battery is connected to the user device directly, please check:

- Whether the DC charging interface of the energy storage inverter meets the charging voltage and current requirements in Table 1-1 Battery Pack Specifications.
- Whether the power of the electrical equipment matches the parameters listed in “Table 1-1 Battery Pack Specifications”;

Security check:

Fire-fighting equipment such as portable dry powder fire extinguishers should be available near the equipment. Do not place dangerous materials such as flammable or explosive ones near the battery.

5.2 Unpacking

- When the battery arrives at the installation site, it must be loaded and unloaded properly and prevented from the direct sunshine and rain. Before installation, check if there is any component missing according to packing list attached in the packing box and check whether the box appearance is intact;
- Carefully handling during the unpacking. Protect the insulated coating on the case surface;
- Check the LFP battery for damage after unpacking. If there is any damage, contact DLG or your reseller.

5.3 The preparatory work

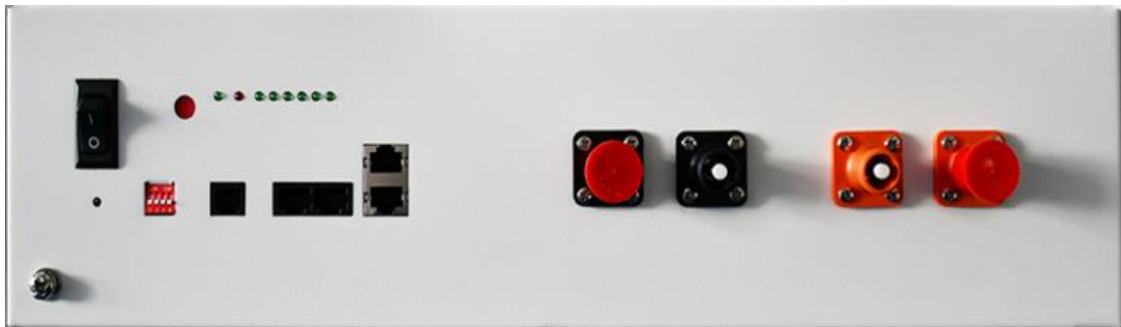

1. Make sure the POWER buttons of all batteries are OFF
2. Ensure the charging voltage of power supply equipment is $DC57.5 \pm 0.1V$;
3. All power supply should be off

5.4 Installation

5.4.1 Install the battery

The E-BOX-48100R can be installed either vertically or horizontally.

In this chapter, it's mainly instructions for horizontal installation such as: installation in a 19-inch cabinet. Vertical installation is similar. All equipment must be steady during installation.

5.4.2 Connect Ground cable

Unscrew the screw at the grounding hole on the front panel of the battery, wrap the ground cable around the screw, and tighten with a screwdriver. Connect the other end of the ground cable to a reliable ground point.

Note: The grounding resistance should be less than 1Ω .

5.4.3 Connecting the power cable

Before connecting the power cable, connect and disconnect the cable to identify the positive and negative terminal, then make a mark respectively. After the cable is connected, measure whether there is a short line or reverse connection.

Connecting the power cables:

(1) Power cable connection instructions of Single-Rack:

- Single battery: Connect the positive pole of the battery to the positive terminal of the DC port of the energy storage inverter (or the junction box) with a red cable, and connect the negative pole of the battery to the negative terminal of the DC port of the energy storage inverter (or the junction box) with a black cable.
- Multiple batteries: the connection between batteries, as well as the connection between the battery and ESS inverter is in parallel. First, connect the two positive terminals of adjacent batteries with the red cable; connect the two negative terminals of adjacent batteries with the black cable; connect the positive pole of the battery with the positive terminal of the DC port of the energy storage inverter (or the junction box) with a red cable; connect the negative pole of the battery with the negative terminal of the DC port of the energy storage inverter (or the junction box) with a black cable.

(2) Power cable connection instructions of multi-Rack:

Collect the positive and negative power cables respectively by the bus bar or junction box, then connect two racks in parallel.

The length, thickness, material, and resistance of the cables connected in parallel should be the same.

Note: When the cable is inserted into the positive and negative terminals of the battery and “Click”, the cable is firmly connected. Before pulling out the cable, press the small button next to the terminal. When multiple batteries are connected in parallel, in order to reduce the influence of the circular current, the overall positive and negative output cables can be connected from different batteries.

Figure 5-2 Schematic diagram of battery connection

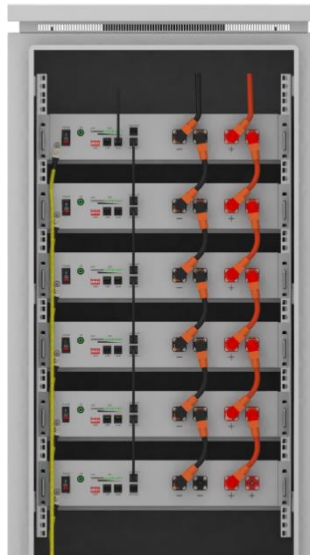

5.4.4 Connecting communication cables

Single battery: Choose which port to be inserted according to the communication protocol (RS485/CAN/RS232) between the battery and ESS inverter, then insert the communication cables to the port;

Multiple batteries: The host and the slave communicate in cascade mode: one is the host and the rest are the slaves. Please refer to the following picture for the cascade connection. then, insert the communication cable to the port according to the communication protocol between batteries and ESS inverter.

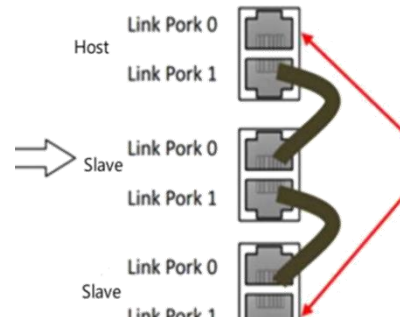

1. The host Link Port 0 must be kept free;
2. The end slave Link Port 1 must be kept free;

5.4.5 Activation

1. Before activation, check again if all cables are properly and firmly connected, also make sure there is no short circuit and reverse connection;

2. Turn all battery POWER buttons to “ON”;

3. Single battery: press the SW button of the battery for 1 second. If the 8 indicator lights of the battery are on for 1 second, the battery is activated.

Multiple batteries: press SW button of any battery for 1 second. If 8 indicator lights of all batteries are on for 1 second, all batteries are activated.

Note: When the battery power is too low to be turned on, charge the battery by connecting the battery to ESS inverter.

5.4.6 Power-on test

1. Turn on the battery and energy storage inverter or DC power supply;

2. Check whether the battery is operating normally by referring to "table 5-3 LED instructions";

1) If the battery is not fully charged and the energy storage inverter has successfully charged the battery, then the battery enters the charging state;

2) If the battery is fully charged and the battery does not supply power to the load, the battery enters the standby state;

3) If the battery is supplying power to the load, the battery enters a discharging state.

Table 5-3 LED indications

Battery status	Protection / Alarm / Normal	RUN	ALM	Capacity LED						Descriptions
		●	●	●	●	●	●	●	●	
Shut down		OFF	OFF	OFF	OFF	OFF	OFF	OFF	OFF	All off
Power-on	Normal	ON	ON	ON	ON	ON	ON	ON	ON	The indicator light is on for about 1 second at power-on.
Standby	Normal	Flash 1	OFF	OFF	OFF	OFF	OFF	OFF	OFF	Indication when the battery is not charging or discharging
	Alarm	OFF	Flash 3	OFF	OFF	OFF	OFF	OFF	OFF	Battery low voltage
Charging	Normal	Light	OFF	According to the power indicator, each LED lamp represents 16.7%SOC, constantly bright means full, off means uncharged, and flicker means charging						
	Alarm	Light	Flash 3							
	Protection	OFF	Light	OFF	OFF	OFF	OFF	OFF	OFF	
Discharge	Normal	Flash 3	Flash 3	According to the power indicator, each LED lamp represents 16.7%SOC,						

Alarm	Flash 3	Flash 3	constantly bright means full, off means uncharged, and flicker means charging						
Protection	OFF	Light	OFF	OFF	OFF	OFF	OFF	OFF	Stop discharge, protect start

Note: The flashing instructions, flash 1-0.25s light/3.75s off; flash 2-0.5s light/0.5s off; flash 3-0.5s light/1.5s off.

---End of installation---

6 Communication

There are RS-232C, RS485 and CAN communication ports on the battery. The battery status can be obtained or the battery internal parameters can be modified via host computer.

6.1 RS232 port

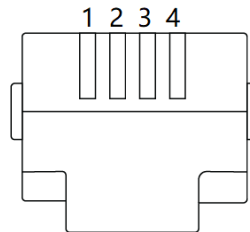

Table 6-1 RS232 Connector Pin Assignments

RS-232C port	
Pin number	Signal
1	GND
2	TXD
3	RXD

4	GND
---	-----

Default baud rate of RS-232C ports: 115200bps.

6.2 RS485 port and CAN port.

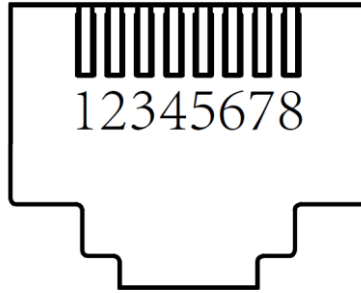

Table 6-2 RS485 and CAN Connector Pin Assignments

Pin number	Serial	CAN
1	RS485B	--
2		GND
3	RS485A	CANH
4	--	CANL
5	--	
6	GND	--
7		--
8		--

Default baud rate of RS-485 port: 115200bps

Default baud rate of CAN port: 500K

7 Troubleshooting

Please refer to the troubleshooting methods mentioned below. Please read the “Table 5 -3 LED indication” of this manual before troubleshooting to prevent false operations. For example, it doesn't indicate the battery is faulty if the ALM alarm red light on the front panel is blinking or constantly on. When there is "alarm" indication, it usually is working normally and needs no troubleshooting. When there is "protection" indication, the battery will work normally automatically after “protection” status is released.



Warning

Do not repair the battery if no authorization from DLG!

7.1 Unable to start

Problem	Troubleshooting Steps	Solution
Press the POWER button to the "ON" state and press the SW button for 1 second, but the LED indicator doesn't respond or all the LEDs are off after 1S.	<ol style="list-style-type: none"> 1. Confirm that the POWER button remains in the "ON" state; 2. Charge the battery correctly and observe if the battery can be charged normally. 	<ol style="list-style-type: none"> 1. If the battery enters charging mode, the battery can return to normal after charging. 2. If not, please contact the dealer or DLG.

7.2 Unable to charge

Problem	Troubleshooting Steps	Solution
The battery cannot be charged properly when the battery is not fully	<ol style="list-style-type: none"> 1. Confirm that the battery is turned on; 2. Check the power cord. Confirm that the power cord is correctly connected and the charging circuit is normal; 	If the battery still does not charge properly after following the above steps, please

charged.	<p>3. Check the battery indicator LED to see if the battery is under “Protection” state. If so, unplug the battery power cord, find the cause of the protection, and fix the problem, then restart the battery;</p> <p>4. Check if the charging voltage meets the battery charging requirements. If not, adjust the power supply voltage to the normal range.</p>	contact the dealer or DLG.
----------	-------------------------------------------------------------------------------------------------------------------------------------------------------------------------------------------------------------------------------------------------------------------------------------------------------------------------------------------------------------------	----------------------------

7.3 Unable to discharge

Problem	Troubleshooting Steps	Solution
The battery cannot be discharged normally.	<p>1. Confirm that the battery is turned on;</p> <p>2. Check the power cord to ensure that the power cord is properly connected.</p> <p>3. Unplug the battery power cord and measure the battery power output voltage. If the battery voltage is too low, charge it immediately.</p> <p>4. Check the battery indicator LED to see if the battery is under “Protection” state. If so, unplug the battery power cord, find the cause of the protection, and fix the problem, then restart the battery;</p>	If the battery still does not discharge properly after following the above steps, please contact the dealer or DLG.

7.4 ALM indicator is always on

When the ALM indicator is constantly red and the other indicators are off, the battery is in “Protection” state which is normal. When the condition which triggered protection is released, the battery will automatically return to normal operation. There are a few issues require immediate measures.

Problem	Troubleshooting Steps	Solution
<p>The ALM indicator is constantly red and all other indicators are off.</p>	<ol style="list-style-type: none"> 1. Check the power cord to ensure that the power cord is properly connected. 2. Check whether the charging voltage, charging/discharging current, battery/cell voltage and temperature meet the relevant protection conditions, and release the “protection” state to ensure that the voltage, current and temperature are within the normal working range. 	<p>If the battery protection state cannot be released, or the ALM indicator is constantly on when the battery is properly charged after the battery is restarted, please contact your dealer or DLG.</p>

DLG (Shanghai) Electronic Technology Co., LTD

 **No.3492 JinqianRoad,Fengxian District,Shanghai,China**

 **021-57474761**

 **ess_support@dlgbattery.cn**